

Fisher™ 2625, 2625SST, and 2625NS Volume Boosters

A Fisher 2625, 2625SST, or 2625NS volume booster is part of the 2625 Series volume boosters and is used in conjunction with a positioner on a throttling control valve to increase stroking speed. The 2625NS is a nuclear-service version and uses elastomeric components that better withstand high temperature and radiation environments.

The booster incorporates fixed deadband, soft seat construction, and an integral bypass restriction to eliminate positioner saturation problems that can occur with volume boosters that do not have these features. Adjustment of the integral bypass restriction is necessary for system stability. This adjustment does not affect the deadband of the volume booster, but does permit the control valve to respond to small input signal changes without sacrificing steady-state accuracy. It also allows the booster to deliver high-volume output for fast stroking when large, rapid input signal changes occur.

The volume booster is used to improve stroking speed. If precision valve control is required, the use of a positioner is recommended. If the volume booster is to be used for on/off control, the integral bypass restriction on the booster must be closed (turned fully clockwise).

Connectors and piping can be installed with either 2625, 2625SST, or 2625NS volume booster for diagnostic testing.

The 2625 and 2625SST are certified for use in Safety Instrumented System (SIS) applications. Certification is by exida Consulting LLC, a global provider of functional safety and control system security. SIS certification is identified on the product by the EXIDA logo on the 2625 nameplate.



W4727-1

Features

- **Fast Response**—Booster delivers the volume needed for rapid actuator stroking when large input changes suddenly occur.
- **Adjustable Response**—Integral bypass restriction tunes the booster response so that smooth actuator motion follows the slow signal changes.
- **Efficient Operation**—Soft seats provide tight shutoff to reduce unnecessary air consumption and eliminate saturation of positioner relays.
- **Maintains Accuracy**—Booster permits high actuator stroking speeds upon demand without degrading the positioner steady-state accuracy.
- **SIL 3 Capable** - Certified for use in Safety Instrumented System (SIS) applications.

Specifications

Supply Pressure Ranges

When used in conjunction with a positioner or other pneumatic accessory, always pipe the positioner and volume booster with one common supply through a Fisher 67D, 67DR, or 95H regulator (see figure 2). A high-capacity filter, such as the Fisher 262K, should be installed in the supply line to the regulator. Supply pressure also must not exceed the maximum pressure rating of the actuator. Constructions are available in two maximum supply ranges.

When Normally Used With Diaphragm Actuators: Up to 2.8 bar (40 psig)

When Normally Used With Piston Actuators: Up to 10.3 bar (150 psig)

Input Signal Pressure

Positioner output

Maximum Input Signal Pressure

10.3 bar (150 psig)

Fixed Input-to-Output Pressure Ratio

1 to 1

Nominal Deadband

Percent of Positioner Output Span⁽¹⁾:
2.4 mm (0.094 inch) exhaust port: 2%
9.5 mm (0.375 inch) exhaust port: 3.5%
12.7 mm (0.5 inch) exhaust port: 5%

Construction Materials

Body: Aluminum or CF8M (316 SST, cast)

Seat Ring: Brass or S31600 (316 SST)

Diaphragms

2625 and 2625SST

Standard: Nitrile/nylon

High Temperature: FKM/TPES

2625

Low Temperature: FVMQ

2625NS: EPDM/meta-aramid

Upper and Lower Valves

2625 and 2625SST

Standard: Nitrile/aluminum/stainless steel

High Temperature: FKM/aluminum/stainless steel

2625

Low Temperature: FVMQ

2625NS: EPDM/aluminum/stainless steel

O-Rings

2625 and 2625SST

Standard: Nitrile

High Temperature: FKM

2625

Low Temperature: FVMQ

2625NS: EPDM

Connectors for Diagnostic Testing: ■ Stainless steel or ■ brass

Operative Temperature Limits⁽²⁾

2625 and 2625SST

Standard: -40 to 71°C (-40 to 160°F)

High Temperature: 0 to 121°C (32 to 250°F)

2625

Low Temperature⁽³⁾: -60 to 65°C (-76 to 149°F)

2625NS: -40 to 93°C (-40 to 200°F)

Connections

Input Signal: 1/4 NPT

Supply and Output: 3/4 NPT

Port Diameters⁽⁴⁾

Supply Port: ■ 9.5 mm (0.375 inch) or

■ 12.7 mm (0.5 inch)

Exhaust Port: ■ 2.4 mm (0.094 inch)⁽⁵⁾,

■ 9.5 mm (0.375 inch) or ■ 12.7 mm (0.5 inch)

Maximum Flow Coefficients

See table 1

Hazardous Area Classification

Complies with the requirements of ATEX Group II Category 2 Gas and Dust

 Ex h IIC Tx Gb
Ex h IIIC Tx Db

Maximum surface temperature (Tx) depends on operating conditions

Gas: T4, T5, T6

Dust: T85...T121

-Continued-

Specifications (continued)

Hazardous Area Classification (continued)

Meets Customs Union technical regulation TP TC 012/2011 for Groups II/III Category 2 equipment

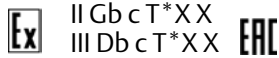

Safety Instrumented System Classification

SIL3 capable - certified by exida Consulting LLC

Approximate Weight

Aluminum: 2.3 kg (5 lb)
Stainless Steel: 4.8 kg (10.6 lb)

NOTE: Specialized instrument terms are defined in ANSI/ISA Standard 51.1 - Process Instrument Terminology.
1. Zero to maximum supply.
2. The pressure/temperature limits in this document and any applicable code or standard should not be exceeded.
3. Low Temperature option only available with CUTR approval.
4. May be used in any combination.
5. Aluminum 2625 volume booster only.

Figure 1. Sectional View of Volume Booster

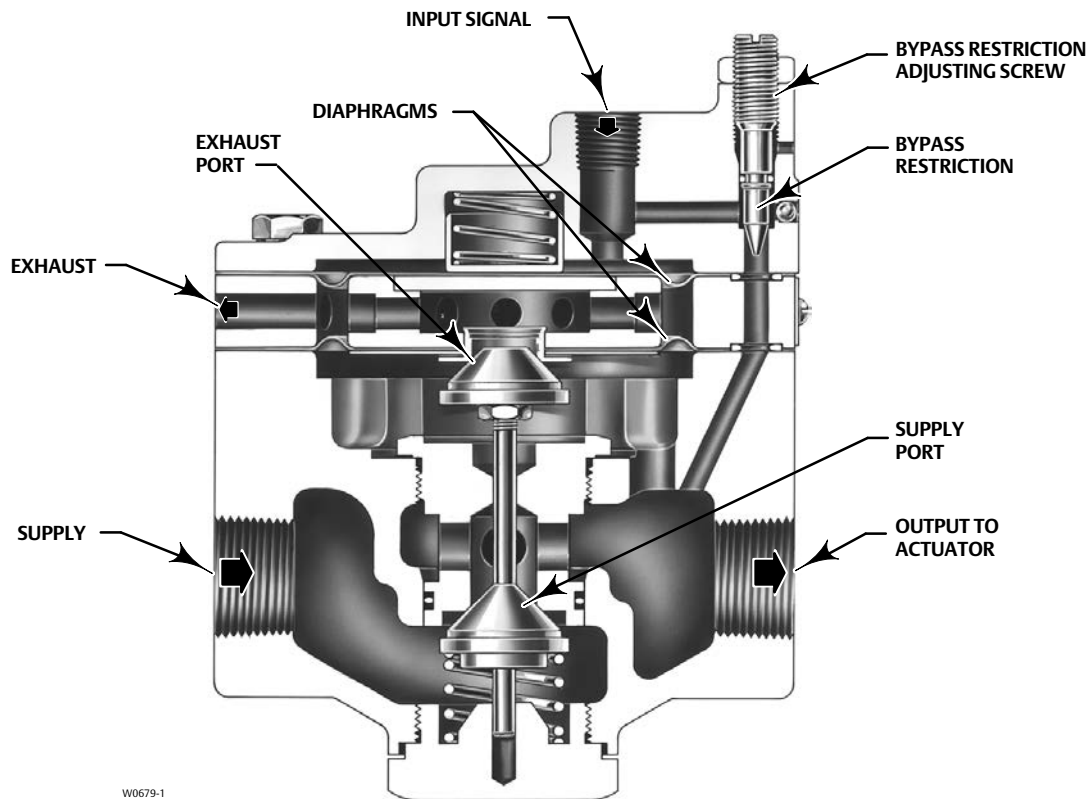

W0679-1

Principle of Operation

Refer to figures 1 and 2. Because of the bypass restriction, large input signal changes register on the booster input diaphragm sooner than in the actuator. A large, sudden change in input signal causes a pressure differential to exist between the input signal and the output of the booster. When this occurs, the diaphragms move to open either the supply port or the exhaust port, whichever action is required to reduce

the differential. The port remains open until the difference between the booster input and output pressures returns to within the deadband limit of the booster. With the bypass restriction adjusted for stable operation, a signal with small magnitude and rate changes passes through the bypass restriction and into the actuator without initiating booster operation.

Both supply and exhaust ports remain closed, preventing unnecessary air consumption and possible saturation of positioner relays.

Figure 2. Typical Installations

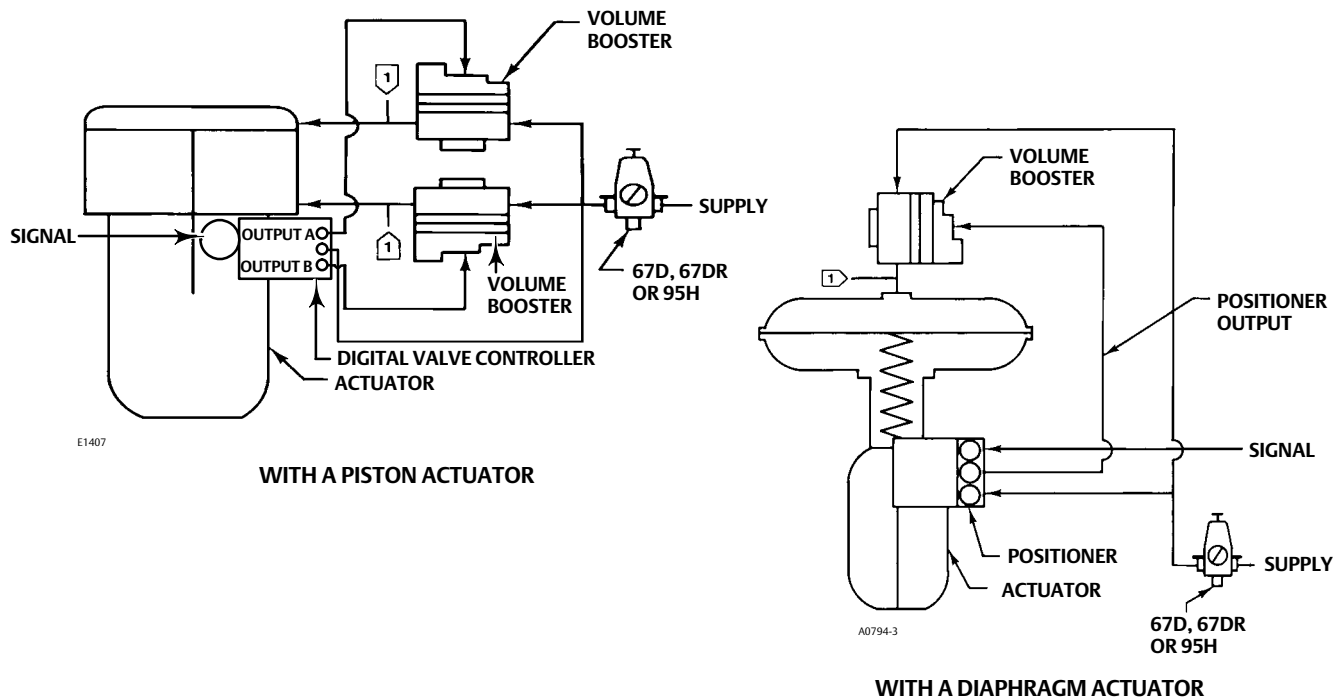

Note:
1 Connection location for diagnostic testing

Table 1. Maximum Flow Coefficients⁽¹⁾

PORT SIZE COMBINATIONS				COEFFICIENTS	
Supply Port		Exhaust Port		Supply Port	Exhaust Port
mm	Inch	mm	Inch	C _v	C _v
9.5	3/8	2.4	3/32	3.74	0.23
		9.5	3/8	3.74	2.29
		12.7	1/2	3.74	3.40
12.7	1/2	2.4	3/32	4.98	0.24
		9.5	3/8	4.98	2.30
		12.7	1/2	4.98	3.40
FIELDVUE™ DVC6200, DVC6200 SIS, DVC6200f, DVC6200p, DVC6000, DVC6000 SIS, DVC6000f digital valve controllers				0.37	0.31
FIELDVUE DVC2000 digital valve controller					
Low Pressure Relay				0.13	0.15
High Pressure Relay				0.19	0.20
Fisher 3570 valve positioner				0.25	0.25
Fisher 3582 valve positioner				0.17	0.19
Fisher 3610J, 3610JP, 3611JP, 3620J, 3620JP, 3621JP valve positioners				0.37	0.30

¹ Consult your [Emerson sales office](#) for special stroking speed requirements.

Figure 3. Dimensions

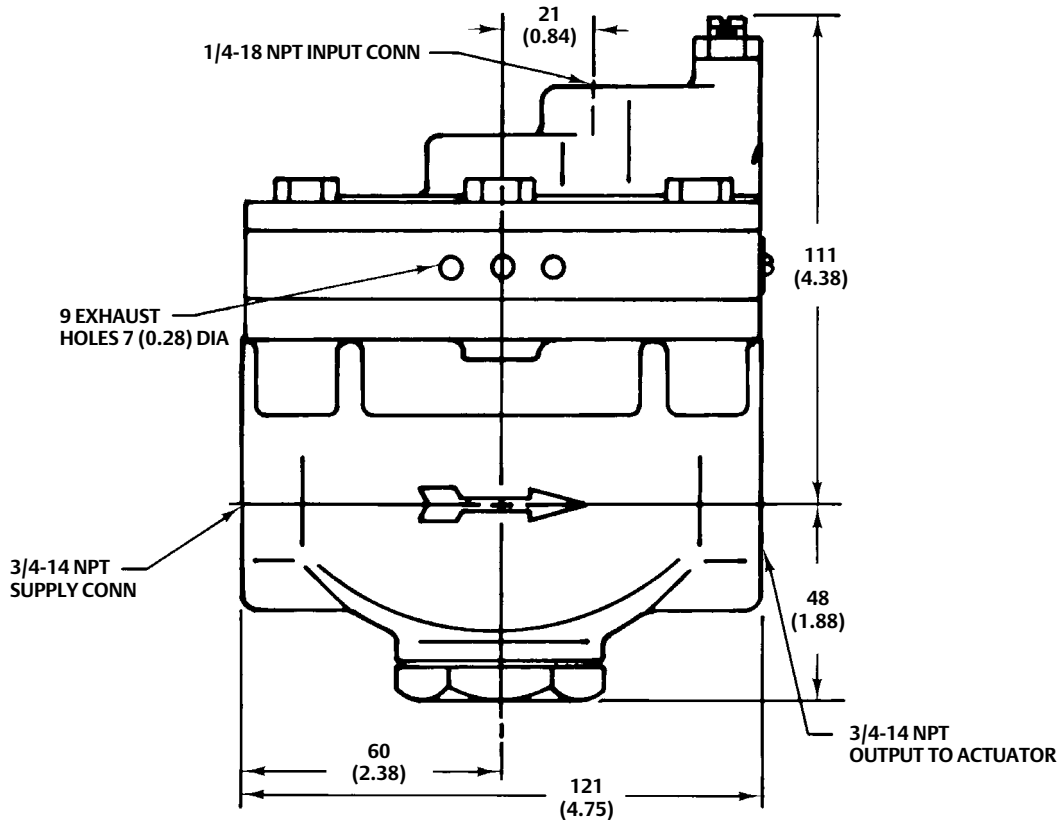

A0807-3

mm
(INCH)

2625NS for Nuclear Service Applications

The 2625NS volume booster uses EPDM (ethylene-propylene) elastomeric parts. These parts have superior resistance to degradation at elevated temperature and radiation levels. This version is designed for nuclear service applications where oil-free supply air is available.

The 2625, 2625SST, and 2625NS are available as safety-related items when processed using the commercial grade dedication section of the 10CFR50, Appendix B, quality assurance program. 10CFR21 reporting is also part of the safety related processing program. Seismic operability testing has been done to qualify both versions as rigid items at levels up to 9g's uniaxial (in each axis). Further nuclear service qualification data is available on request.

Installation

Figure 2 shows typical installations for the 2625, 2625SST, or 2625NS volume booster on piston and diaphragm actuators. A single regulator that supplies both the positioner and booster (or boosters) is recommended. The supply medium must be clean, dry, oil-free air or non-corrosive gas.

Note

Use a clean, dry, oil-free air supply with instruments containing EPDM components. EPDM is subject to degradation when exposed to petroleum-base lubricants.

Keep in mind that many actuators require larger casing or cylinder connections to take full advantage of the booster's ability to deliver its high-volume output. Dimensions are shown in figure 3. Ensure that the supply pressure is connected to correspond with the flow arrow on the booster.

Ordering Information

When ordering, specify:

1. Aluminum or stainless steel
2. Supply and exhaust port sizes. See table 1 for Cv values.
3. Supply pressure range of up to 2.8 bar (40 psig) or up to 10.3 bar (150 psig).
4. Stroking speed information when being mounted at the factory, for proper tuning of the instruments. Specify either critical or non-critical stroke speed time.

Note

Critical stroke speed time example: Valve to stroke in both directions in 4 seconds or less.

Non-critical stroke speed time example: Valve to stroke in approximately 4 seconds in both directions.

5. Nuclear service, if applicable. Consult your [Emerson sales office](#) for ordering assistance.

Neither Emerson, Emerson Automation Solutions, nor any of their affiliated entities assumes responsibility for the selection, use or maintenance of any product. Responsibility for proper selection, use, and maintenance of any product remains solely with the purchaser and end user.

Fisher and FIELDVUE are marks owned by one of the companies in the Emerson Automation Solutions business unit of Emerson Electric Co. Emerson Automation Solutions, Emerson, and the Emerson logo are trademarks and service marks of Emerson Electric Co. All other marks are the property of their respective owners.

The contents of this publication are presented for informational purposes only, and while every effort has been made to ensure their accuracy, they are not to be construed as warranties or guarantees, express or implied, regarding the products or services described herein or their use or applicability. All sales are governed by our terms and conditions, which are available upon request. We reserve the right to modify or improve the designs or specifications of such products at any time without notice.

Emerson Automation Solutions
Marshalltown, Iowa 50158 USA
Sorocaba, 18087 Brazil
Cernay, 68700 France
Dubai, United Arab Emirates
Singapore 128461 Singapore

www.Fisher.com

